

# TETRARACK M2 HD

## TETRARACK M2 HD (SEATSTAYS)

MAX LOAD IN TOTAL 22KG



- 1 Frame
- 2 Rack Slide rail
- 3 Angle adjustment
- 4 Velcro straps
- 5 Reflective bracket
- 6 Allen key 3mm x 1
- 7 Bottle cage mount
- 8 Strap tensioner
- 9 Rubber pad

- 1 Rama
- 2 Boczne przęty
- 3 Regulacja kąta
- 4 Paski rzepowe
- 5 Uchwyty odbłasku
- 6-1 Uchwyt do lampy
- 6 Imbus 3mm x 1
- 7 Uchwyt na koszyk bidonu
- 8 Napinacz paska
- 9 Gumowa podkładka

- 1 Trägerplatte
- 2 Gleitschiene
- 3 Winkelverstellung
- 4 Klettgurte
- 5 Reflektorhalterung
- 5-1 Rückklinalhalterung
- 6 1x 3 mm Innensechskant-Schlüssel
- 7 Flaschenhalteraufnahme
- 8 Gurtschrafer
- 9 Gummipad

- 1 Cadre
- 2 rail à glissière
- 3 Réglae de l'angle
- 4 sangle et crochet
- 5 réflecteur de lumière
- 5-1 Tail Light Mount
- 6 clé Allen de 3mm x 1
- 7 Fixation de porte bidon
- 8 tendeur de sangle
- 9 cossinet en caoutchouc

- 1 Estructura
- 2 Binarrio di scorrimento
- 3 Regolazione angolare
- 4 Cinturini con velcro
- 5 Staffa riflettente
- 5-1 Staffa per fanalino posteriore
- 6 Chave a brugula 3mm x 1
- 7 Attacco portaborraccia
- 8 Tendenciahija
- 9 Cuscinetto in gomma

- 1 貨架框架
- 2 貨架滑軌
- 3 固定基座角度調整
- 4 束帶
- 5 反光片取附
- 5-1 寬型尾燈取附
- 6 3mm六角扳手
- 7 水壺架安裝
- 8 束帶調整
- 9 橡膠墊片

- 1 貨架框架
- 2 貨架滑軌
- 3 固定基座角度調整
- 4 束帶
- 5 反光片取附
- 5-1 寬型尾燈取附
- 6 3mm六角扳手
- 7 水壺架安裝
- 8 束帶調整
- 9 橡膠墊片

- 1 貨架框架
- 2 貨架滑軌
- 3 固定基座角度調整
- 4 束帶
- 5 反光片取附
- 5-1 寬型尾燈取附
- 6 3mm六角扳手
- 7 水壺架安裝
- 8 束帶調整
- 9 橡膠墊片

- 1 貨架框架
- 2 貨架滑軌
- 3 固定基座角度調整
- 4 束帶
- 5 反光片取附
- 5-1 寬型尾燈取附
- 6 3mm六角扳手
- 7 水壺架安裝
- 8 束帶調整
- 9 橡膠墊片

- 1 貨架框架
- 2 貨架滑軌
- 3 固定基座角度調整
- 4 束帶
- 5 反光片取附
- 5-1 寬型尾燈取附
- 6 3mm六角扳手
- 7 水壺架安裝
- 8 束帶調整
- 9 橡膠墊片

### WARNING

• Maximum weight capacity: 22kg / 48 lb  
 • Wheel size compatibility: 27.5" - 29"  
 • Tire width compatibility: ≤ 2.8"  
 • Width compatibility: Seatstays 95-125mm

• Max. Belastung: 22 kg  
 • Kompatible Laufringgrößen: 27.5" - 29"  
 • Kompatible Reifenbreiten: ≤ 2.8"  
 • Kompatible Breiten: Sitzstreben 95 - 125mm

• Charge Maximal supportée: 22kg / 48 lb  
 • Taille de roue compatible: 27.5" - 29"  
 • Largeur de pneu maximale: 2.8"  
 • Largeur compatible: hauban 95-125mm

• Capacidad máxima de peso: 22kg / 48 lb  
 • Compatible con radios de 27.5" - 29"  
 • Anchura compatible: varas 95-125mm

• Peso massimo: 22 kg / 48 lb  
 • Dimensione ruota compatibile: 27.5" - 29"  
 • Larghezza copertoni compatibile: ≤ 2.8"  
 • Interscambio c/codiici verticali: 95-125mm

• Maksymalny udźwóg: 22 kg / 48 lb  
 • Kompatybilność rozmiarów kół: 27.5" - 29"  
 • Kompatybilność z szerokością opon: ≤ 2.8"  
 • Kompatybilność z szerokością: tylny trójróg 95-125mm

### WARNING / AVERTISSEMENT / ADVERTENCIA / ATTENZIONE / UWAGA / 注意 / 경고 / 注意

• 静止状態での耐荷重: 22kg  
 • 対応ホイールサイズ: 27.5" - 29"  
 • 対応タイヤ幅: 2.8"以下  
 • 対応幅: シートステー 95~125mm

• 최대 적재 하중: 22 kg / 48 lb  
 • 호환 휠 사이즈: 27.5" - 29"  
 • 호환 타이어 폭: 2.8" 이하  
 • 호환 너비: 시트스테이 95-125mm

• 最大承重: 22 kg / 48 lb  
 • 兼容尺寸兼容性: 27.5" - 29"  
 • 輪胎寬度兼容性: ≤ 2.8"  
 • 寬度兼容性: 後上叉95-125mm

• 最大承重: 22 kg / 48 lb  
 • 車輪尺寸兼容性: 27.5" - 29"  
 • 輪胎寬度兼容性: ≤ 2.8"  
 • 高度兼容性: 后上叉95-125mm

• Maksymalny udźwóg: 22 kg / 48 lb  
 • Kompatybilność rozmiarów kół: 27.5" - 29"  
 • Kompatybilność z szerokością opon: ≤ 2.8"  
 • Kompatybilność z szerokością: tylny trójróg 95-125mm

### QUICK MOUNT STRAP + DROPOUT EYELET MOUNT

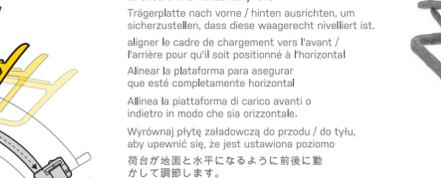
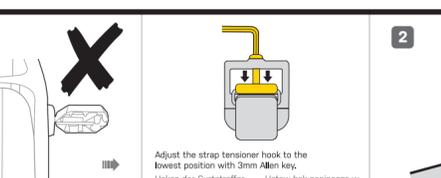

Tail Light Mount is used for mounting rear lights with 80mm (center to center) mounting holes on TetraRack.

Rückklinalhalterung zur Montage von Rücklichtern mit 80 mm Gewindeabstand (Mitte-Mitte) am TetraRack.

La Tail Light Mount est utilisé pour monter un éclairage arrière fournis de trous de fixation de 80 mm (centre à centre) sur les portabidons TetraRack.

El soporte para luces traseras tiene agujeros de montaje de 80 mm (de centro a centro) para su instalación en el portaequipajes TetraRack. (Corrected it)

La staffa per il fanalino posteriore (Tail Lite Mount) è predisposta con due fori distanti 80 mm (da centro a centro) per il montaggio su TetraRack.

Uchwyt do lampy służy do montażu tylnego oświetlenia z otworami montażowymi 80 mm (od środka do środka) na TetraRack.

テールライトマウントには取付間隔が80mm（中心から中心まで）のテールライトが取り付け可能です。

寬型尾燈取附用於將較大型的尾燈安裝至TetraRack。其兩個螺絲孔（中心處至中心處）的距離為80mm。

寬型尾燈取附適用於將較大型的尾燈安裝至TetraRack。其兩個螺絲孔（中心處至中心處）的距離為80mm。

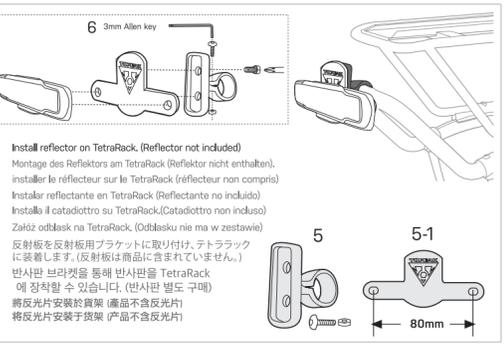

### Compatible seatstay Width capacity 95 - 125 mm

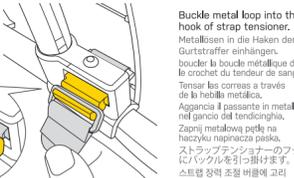
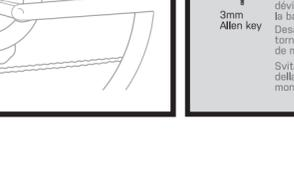
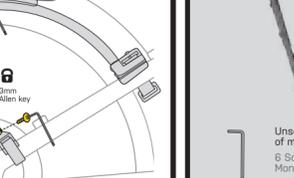
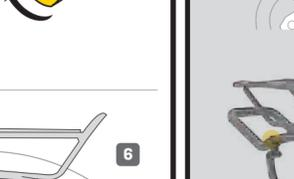
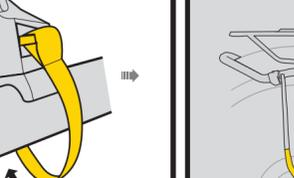
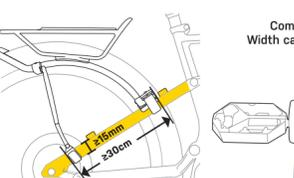

### NOTE

Clean frame / fork mounting area prior to installing TetraRack.

Montagebereich an der Gabel / am Rahmen vor der Montage des TetraRacks reinigen.

nettoyer la zone de fixation de la fourche / cadre avant d'installer le TetraRack.

Limpier el área de montaje del cuadro y la horquilla antes de instalar el TetraRack.

Pulire l'area di montaggio sulla forcella o sui forconi prima di montare TetraRack.

Compatible with Topeak QuickTrack® system TrunkBags / TrunkBags and KlicKix® / Racktime® Snapit or Vario system bags

Kompatybilne z systemem Topeak QuickTrack® TrunkBags / TrunkBags i KlicKix® / Racktime® Snapit lub systemami torb Vario

Compatible with Topeak MTX 1.0 & 2.0 TrunkBags sowie Systemtaschen mit KlicKix® / racktime® Snapit 1.0 / Vario-Adapter (alle)

Compatible with the fivation Topeak QuickTrack pour trunkbags / trunkbox et klicKix® / racktime Snapit ou les sacs possédant une fixation Vario.

Compatible con i sistemi Topeak QuickTrack per borse TrunkBags / TrunkBox y KlicKix® / Racktime Snapit o sistemas Vario

Compatible con i sistemi di borse Topeak QuickTrack® / TrunkBags / TrunkBox e KlicKix® / Racktime® Snapit o Vario

Compatible with Topeak QuickTrack® system TrunkBags / TrunkBags and KlicKix® / Racktime® Snapit or Vario system bags

Kompatybilne z systemem Topeak QuickTrack® TrunkBags / TrunkBags i KlicKix® / Racktime® Snapit lub systemami torb Vario

Compatible with Topeak MTX 1.0 & 2.0 TrunkBags sowie Systemtaschen mit KlicKix® / racktime® Snapit 1.0 / Vario-Adapter (alle)

Compatible with the fivation Topeak QuickTrack pour trunkbags / trunkbox et klicKix® / racktime Snapit ou les sacs possédant une fixation Vario.

Compatible con i sistemi Topeak QuickTrack per borse TrunkBags / TrunkBox y KlicKix® / Racktime Snapit o sistemas Vario

Compatible con i sistemi di borse Topeak QuickTrack® / TrunkBags / TrunkBox e KlicKix® / Racktime® Snapit o Vario

Compatible with Topeak QuickTrack® system TrunkBags / TrunkBags and KlicKix® / Racktime® Snapit or Vario system bags

Kompatybilne z systemem Topeak QuickTrack® TrunkBags / TrunkBags i KlicKix® / Racktime® Snapit lub systemami torb Vario

Compatible with Topeak MTX 1.0 & 2.0 TrunkBags sowie Systemtaschen mit KlicKix® / racktime® Snapit 1.0 / Vario-Adapter (alle)

Compatible with the fivation Topeak QuickTrack pour trunkbags / trunkbox et klicKix® / racktime Snapit ou les sacs possédant une fixation Vario.

Compatible con i sistemi Topeak QuickTrack per borse TrunkBags / TrunkBox y KlicKix® / Racktime Snapit o sistemas Vario

Compatible con i sistemi di borse Topeak QuickTrack® / TrunkBags / TrunkBox e KlicKix® / Racktime® Snapit o Vario

Compatible with Topeak QuickTrack® system TrunkBags / TrunkBags and KlicKix® / Racktime® Snapit or Vario system bags

Kompatybilne z systemem Topeak QuickTrack® TrunkBags / TrunkBags i KlicKix® / Racktime® Snapit lub systemami torb Vario

Compatible with Topeak MTX 1.0 & 2.0 TrunkBags sowie Systemtaschen mit KlicKix® / racktime® Snapit 1.0 / Vario-Adapter (alle)

Compatible with the fivation Topeak QuickTrack pour trunkbags / trunkbox et klicKix® / racktime Snapit ou les sacs possédant une fixation Vario.

Compatible con i sistemi Topeak QuickTrack per borse TrunkBags / TrunkBox y KlicKix® / Racktime Snapit o sistemas Vario

Compatible con i sistemi di borse Topeak QuickTrack® / TrunkBags / TrunkBox e KlicKix® / Racktime® Snapit o Vario

Compatible with Topeak QuickTrack® system TrunkBags / TrunkBags and KlicKix® / Racktime® Snapit or Vario system bags

Kompatybilne z systemem Topeak QuickTrack® TrunkBags / TrunkBags i KlicKix® / Racktime® Snapit lub systemami torb Vario

Compatible with Topeak MTX 1.0 & 2.0 TrunkBags sowie Systemtaschen mit KlicKix® / racktime® Snapit 1.0 / Vario-Adapter (alle)

Compatible with the fivation Topeak QuickTrack pour trunkbags / trunkbox et klicKix® / racktime Snapit ou les sacs possédant une fixation Vario.

Compatible con i sistemi Topeak QuickTrack per borse TrunkBags / TrunkBox y KlicKix® / Racktime Snapit o sistemas Vario

Compatible con i sistemi di borse Topeak QuickTrack® / TrunkBags / TrunkBox e KlicKix® / Racktime® Snapit o Vario

Compatible with Topeak QuickTrack® system TrunkBags / TrunkBags and KlicKix® / Racktime® Snapit or Vario system bags

Kompatybilne z systemem Topeak QuickTrack® TrunkBags / TrunkBags i KlicKix® / Racktime® Snapit lub systemami torb Vario

Compatible with Topeak MTX 1.0 & 2.0 TrunkBags sowie Systemtaschen mit KlicKix® / racktime® Snapit 1.0 / Vario-Adapter (alle)

Compatible with the fivation Topeak QuickTrack pour trunkbags / trunkbox et klicKix® / racktime Snapit ou les sacs possédant une fixation Vario.

Compatible con i sistemi Topeak QuickTrack per borse TrunkBags / TrunkBox y KlicKix® / Racktime Snapit o sistemas Vario

Compatible con i sistemi di borse Topeak QuickTrack® / TrunkBags / TrunkBox e KlicKix® / Racktime® Snapit o Vario

Compatible with Topeak QuickTrack® system TrunkBags / TrunkBags and KlicKix® / Racktime® Snapit or Vario system bags

Kompatybilne z systemem Topeak QuickTrack® TrunkBags / TrunkBags i KlicKix® / Racktime® Snapit lub systemami torb Vario

Compatible with Topeak MTX 1.0 & 2.0 TrunkBags sowie Systemtaschen mit KlicKix® / racktime® Snapit 1.0 / Vario-Adapter (alle)

Compatible with the fivation Topeak QuickTrack pour trunkbags / trunkbox et klicKix® / racktime Snapit ou les sacs possédant une fixation Vario.

Compatible con i sistemi Topeak QuickTrack per borse TrunkBags / TrunkBox y KlicKix® / Racktime Snapit o sistemas Vario

Compatible con i sistemi di borse Topeak QuickTrack® / TrunkBags / TrunkBox e KlicKix® / Racktime® Snapit o Vario

Compatible with Topeak QuickTrack® system TrunkBags / TrunkBags and KlicKix® / Racktime® Snapit or Vario system bags

Kompatybilne z systemem Topeak QuickTrack® TrunkBags / TrunkBags i KlicKix® / Racktime® Snapit lub systemami torb Vario

Compatible with Topeak MTX 1.0 & 2.0 TrunkBags sowie Systemtaschen mit KlicKix® / racktime® Snapit 1.0 / Vario-Adapter (alle)

Compatible with the fivation Topeak QuickTrack pour trunkbags / trunkbox et klicKix® / racktime Snapit ou les sacs possédant une fixation Vario.

Compatible con i sistemi Topeak QuickTrack per borse TrunkBags / TrunkBox y KlicKix® / Racktime Snapit o sistemas Vario

Compatible con i sistemi di borse Topeak QuickTrack® / TrunkBags / TrunkBox e KlicKix® / Racktime® Snapit o Vario

Compatible with Topeak QuickTrack® system TrunkBags / TrunkBags and KlicKix® / Racktime® Snapit or Vario system bags

Kompatybilne z systemem Topeak QuickTrack® TrunkBags / TrunkBags i KlicKix® / Racktime® Snapit lub systemami torb Vario

Compatible with Topeak MTX 1.0 & 2.0 TrunkBags sowie Systemtaschen mit KlicKix® / racktime® Snapit 1.0 / Vario-Adapter (alle)

Compatible with the fivation Topeak QuickTrack pour trunkbags / trunkbox et klicKix® / racktime Snapit ou les sacs possédant une fixation Vario.

Compatible con i sistemi Topeak QuickTrack per borse TrunkBags / TrunkBox y KlicKix® / Racktime Snapit o sistemas Vario

Compatible con i sistemi di borse Topeak QuickTrack® / TrunkBags / TrunkBox e KlicKix® / Racktime® Snapit o Vario

Compatible with Topeak QuickTrack® system TrunkBags / TrunkBags and KlicKix® / Racktime® Snapit or Vario system bags

Kompatybilne z systemem Topeak QuickTrack® TrunkBags / TrunkBags i KlicKix® / Racktime® Snapit lub systemami torb Vario

Compatible with Topeak MTX 1.0 & 2.0 TrunkBags sowie Systemtaschen mit KlicKix® / racktime® Snapit 1.0 / Vario-Adapter (alle)

Compatible with the fivation Topeak QuickTrack pour trunkbags / trunkbox et klicKix® / racktime Snapit ou les sacs possédant une fixation Vario.

Compatible con i sistemi Topeak QuickTrack per borse TrunkBags / TrunkBox y KlicKix® / Racktime Snapit o sistemas Vario

Compatible con i sistemi di borse Topeak QuickTrack® / TrunkBags / TrunkBox e KlicKix® / Racktime® Snapit o Vario

Compatible with Topeak QuickTrack® system TrunkBags / TrunkBags and KlicKix® / Racktime® Snapit or Vario system bags

Kompatybilne z systemem Topeak QuickTrack® TrunkBags / TrunkBags i KlicKix® / Racktime® Snapit lub systemami torb Vario

Compatible with Topeak MTX 1.0 & 2.0 TrunkBags sowie Systemtaschen mit KlicKix® / racktime® Snapit 1.0 / Vario-Adapter (alle)

Compatible with the fivation Topeak QuickTrack pour trunkbags / trunkbox et klicKix® / racktime Snapit ou les sacs possédant une fixation Vario.

Compatible con i sistemi Topeak QuickTrack per borse TrunkBags / TrunkBox y KlicKix® / Racktime Snapit o sistemas Vario

Compatible con i sistemi di borse Topeak QuickTrack® / TrunkBags / TrunkBox e KlicKix® / Racktime® Snapit o Vario

Compatible with Topeak QuickTrack® system TrunkBags / TrunkBags and KlicKix® / Racktime® Snapit or Vario system bags

Kompatybilne z systemem Topeak QuickTrack® TrunkBags / TrunkBags i KlicKix® / Racktime® Snapit lub systemami torb Vario

Compatible with Topeak MTX 1.0 & 2.0 TrunkBags sowie Systemtaschen mit KlicKix® / racktime® Snapit 1.0 / Vario-Adapter (alle)

Compatible with the fivation Topeak QuickTrack pour trunkbags / trunkbox et klicKix® / racktime Snapit ou les sacs possédant une fixation Vario.

Compatible con i sistemi Topeak QuickTrack per borse TrunkBags / TrunkBox y KlicKix® / Racktime Snapit o sistemas Vario

Compatible con i sistemi di borse Topeak QuickTrack® / TrunkBags / TrunkBox e KlicKix® / Racktime® Snapit o Vario

Compatible with Topeak QuickTrack® system TrunkBags / TrunkBags and KlicKix® / Racktime® Snapit or Vario system bags

Kompatybilne z systemem Topeak QuickTrack® TrunkBags / TrunkBags i KlicKix® / Racktime® Snapit lub systemami torb Vario

Compatible with Topeak MTX 1.0 & 2.0 TrunkBags sowie Systemtaschen mit KlicKix® / racktime® Snapit 1.0 / Vario-Adapter (alle)

Compatible with the fivation Topeak QuickTrack pour trunkbags / trunkbox et klicKix® / racktime Snapit ou les sacs possédant une fixation Vario.

Compatible con i sistemi Topeak QuickTrack per borse TrunkBags / TrunkBox y KlicKix® / Racktime Snapit o sistemas Vario

Compatible con i sistemi di borse Topeak QuickTrack® / TrunkBags / TrunkBox e KlicKix® / Racktime® Snapit o Vario

### INSTALLATION

### MONTAGE / INSTALACIÓN / MONTAJ / 取付方法 / 정작 / 安裝

#### QUICK MOUNT

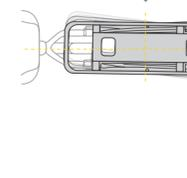
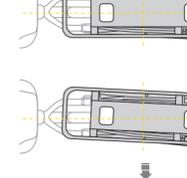
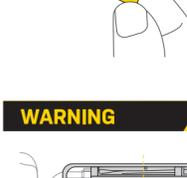
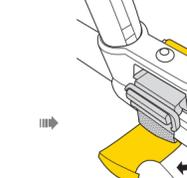
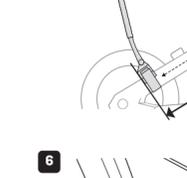
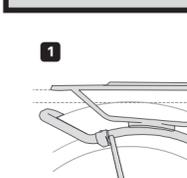
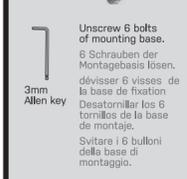
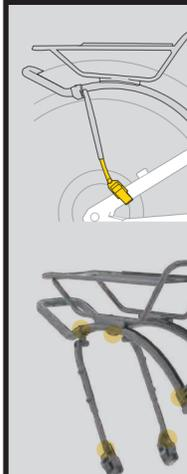

#### QUICK MOUNT + DROPOUT EYELET MOUNT

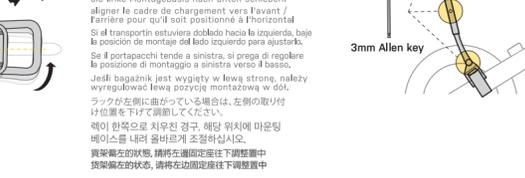
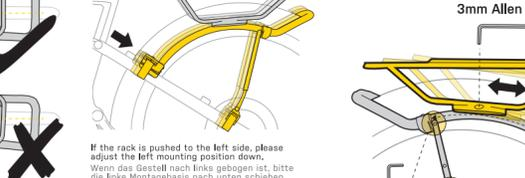
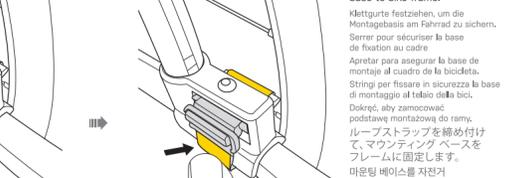
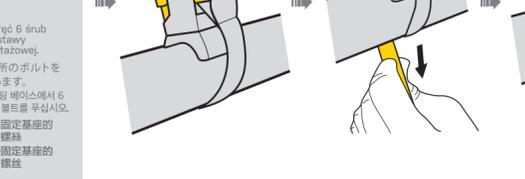
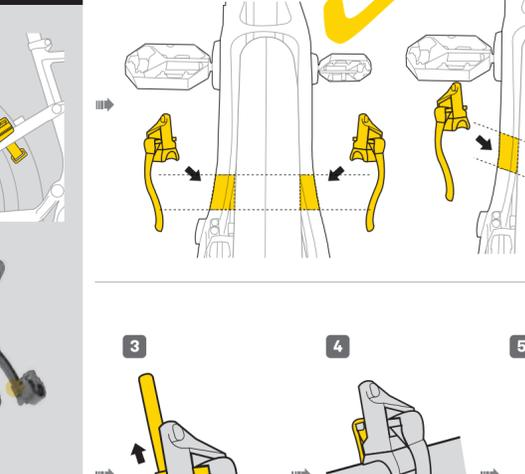

#### ANGLE ADJUSTMENT

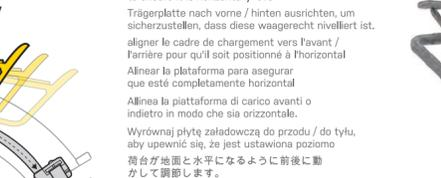
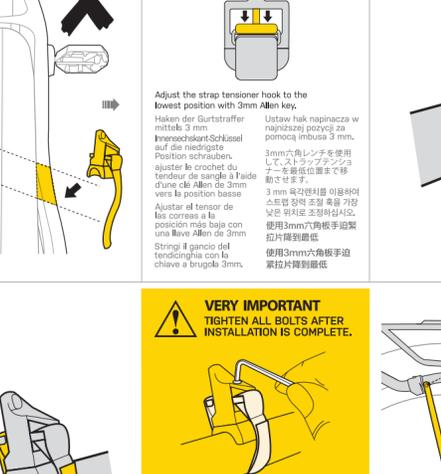

#### VERY IMPORTANT

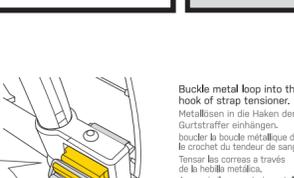
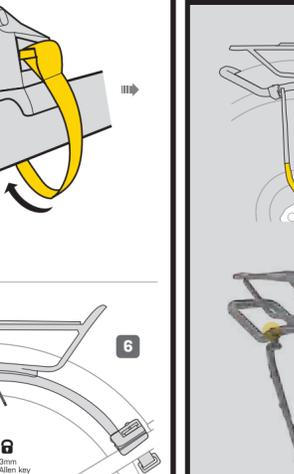

#### IMPORTANT NOTE

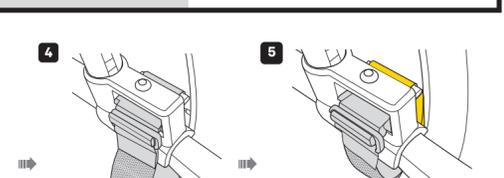
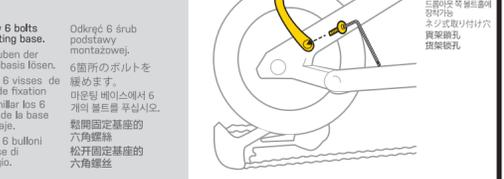
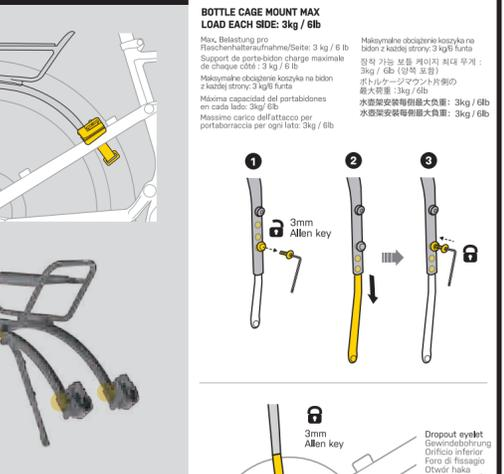

### WARNING

### ACHTUNG / AVERTISSEMENT / ADVERTENCIA / ATTENZIONE / UWAGA / 注意 / 경고 / 注意

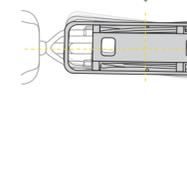
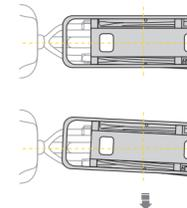

#### Align the loading plate fore / aft to ensure it is horizontally level

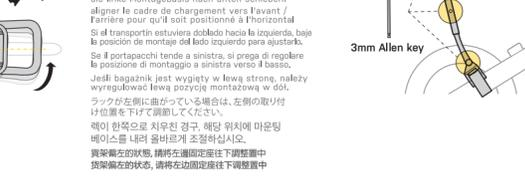
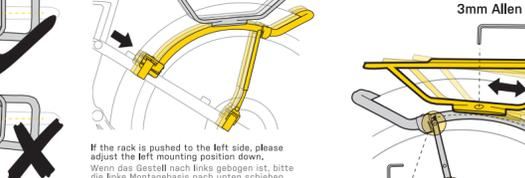

#### Align the loading plate fore / aft to ensure it is horizontally level

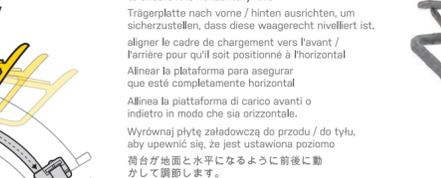

#### Align the loading plate fore / aft to ensure it is horizontally level



#### Align the loading plate fore / aft to ensure it is horizontally level



#### Recommended Torque Value

Empfohlenes Drehmoment  
Couple recommandé  
Par de apriete recomendado  
Zalecany moment obrotowy

推奨トルク  
추진 토크 입력  
建議力  
建議扭矩

4 Nm



## ANGLE ADJUSTMENT

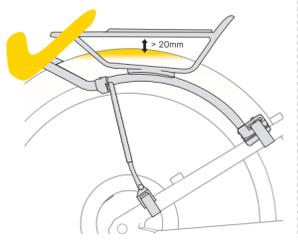

The proper tire clearance must be larger than 20mm. Improper tire clearance may cause damage to TetraRack, your bike, or body injury. Der Reifenabstand von muss mind. 20 mm betragen. Unzureichender Reifenabstand kann zu Schäden am TetraRack, dem Fahrrad oder zu Verletzungen des Fahrers führen.

L'écart nécessaire au bon fonctionnement du doit être supérieur à 20mm, un écart insuffisant peut causer des dégâts au TetraRack, au vélo ou des dégâts corporel.

El espacio de separación apropiado del neumático y el transportín debe ser superior a 20mm. Si el espacio fuera menor, podría causar daños en el transportín, en su bicicleta e incluso en el ciclista.

Il margine appropriato tra il copertone e dev'essere di almeno 20mm. Un margine inadeguato può causare danni a TetraRack, alla bici o al ciclista.



Właściwy prześwit opony w musi być większy niż 20 mm. Za mały prześwit może spowodować uszkodzenie TetraRack, roweru lub obrażenia ciała.

テトララックタイヤのクリアランスは必ず20mm以上設けてください。タイヤのクリアランスが適切でない場合、怪我や事故の原因となる恐れがあります。

의적절한 타이어 간격은 20mm보다 높아야 합니다. 타이어 간격이 부적절하면 TetraRack과 자전거 또는 라이더 몸에 부상을 입을 수 있습니다.

輪胎間隙必須大於2公分，錯誤的角度及輪胎間隙可能造成產品或機車損壞，並危及人身安全。

輪胎間隙必須大於2公分，錯誤的角度及輪胎間隙可能造成產品或機車損壞，並危及人身安全。

## FRONT FORK / SEATSTAY

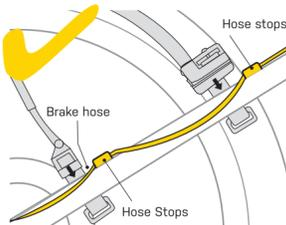

Do not install the rack on screw holes, hose stops, or brake hose.

Montagebasen nicht auf Gewindebohrungen, Leitungsführungen und Bremsleitungen montieren.

ne pas installer le porte paquet sur un pas de visse, une durite ou un arrêt pour gaine de frein

No instalar el transportin en los agujeros de las vainas, o encima de las guías o de los frenos.

Non installare il portapacchi su alloggi per viti, ferme cavi, o cavi freno.

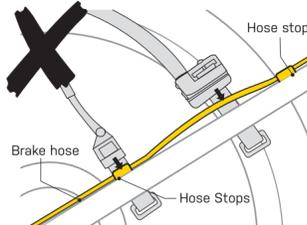

Nie montuj bagażnika na otworach na śruby, ogranicznikach pancerzy lub pancerzach hamulcowych.

アウター受けやブレーキケーブル、ネジ穴などの上にラックを取り付けないでください。

나사 홀, 호스 스톱 또는 브레이크 호스에 랙을 설치하지 마십시오.

不要將貨架安裝在止栓與煞車線上。

不要將貨架安裝在止栓與煞車線上。

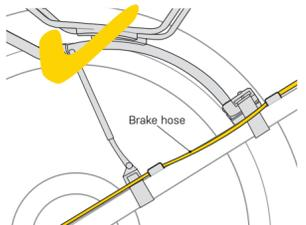

When fixing mounting straps, do not inadvertently tighten over brake hose or derailleur cable

Klettverschlüsse bei der Montage nicht über der Bremsleitung und dem Schaltzug schließen.

Lors de la fixation des sangles de fixation, veuillez à ne pas serrer une gaine de frein ou de dérailleur par inadvertance.

Al instalar las correas, tenga cuidado de no apretarlas por encima de los frenos o del cable del desviador.

Durante il fissaggio dei cinturini, non stringere accidentalmente attorno ai cavi freno o deragiatore.

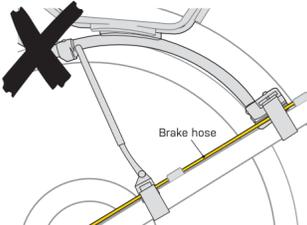

Montując paski montażowe nie należy przypadkowo napinać przewodu hamulcowego lub linki przerzutki

ストラップを固定する際、ブレーキケーブルやシフトケーブルを巻き込まないようにしてください。

스트랩을 고정할 때 브레이크 호스나 변속 케이블 위에 걸치지 마십시오.

固定貨架束帶時，不要將煞車線綁在一起。

固定貨架束帶時，不要將煞車線綁在一起。

## OPTIONAL ACCESSORIES

OPTIONALES ZUBEHÖR/ ACCE SSOIRES EN OPTION/ ACCESORIOS OPCIONALES/ ACCESSORI OPZIONALI/ オプション アクセサリー/ 별도 구매 장착 가능 액세서리

sold separately/ einzeln erhältlich/ vendus séparément/ vendido por separado/venduto separatamente/ 別売品 / 另外購買 / 另外购买

\*not available in Germany / \*nicht in Deutschland erhältlich

## TETRARACK M1



## TETRARACK M2 / M2L / M2 HD



## WARNING NOTES

- Clean frame/fork mounting area prior to installing TetraRack.
- Never exceed maximum loading capacity when using TETRARACK M2 HD ( 35 lb / 16 kg ) and bottle cage mount max load each side: 6lb / 3kg
- Check TetraRack after every ride for secure mounting. If there is any exaggerated movement of TetraRack during a ride, stop riding immediately.
- Do not engage in extreme riding, such as jumping, when using TetraRack
- Do not attempt to use TETRARACK as a passenger seat.
- Always balance the load on TetraRack. Do not install a pannier bag only on one side of TetraRack.

## SICHERHEITSHINWEISE

- Montagebereiche an der Gabel / am Rahmen vor der Montage des TetraRacks reinigen.
- Maximale Belastung des TetraRack M2 HD (16 kg) und der Flaschenhalteraufnahmen (max. 3 kg pro Seite) niemals überschreiten.
- TetraRack nach jeder Fahrt auf eine sichere Montage überprüfen. Die Fahrt sofort stoppen, sollte sich der TetraRack während der Fahrt übermäßig bewegen.
- Bei der Verwendung des TetraRacks keine extremen fahrmánöver, wie z.B. Sprünge, durchführen.
- TetraRack niemals als Sitz- oder Transportfläche für Personen verwenden.
- Last auf dem TetraRack immer ausbalancieren. Gepäckträgeraschen immer beidseitig montieren.

## NOTES D'AVERTISSEMENT

- Nettoyez la zone de montage du cadre/fourche avant d'installer le TetraRack.
- Ne dépassez jamais la capacité de charge maximale lors de l'utilisation du TETRARACK M2 HD (35 lb / 16 kg) et de la charge maximale de chaque côté du support de cage à bouteille : 6 lb / 3 kg.
- Vérifiez le TetraRack après chaque trajet pour vous assurer d'un montage sécurisé. Si vous constatez un mouvement exagéré du TetraRack pendant un trajet, arrêtez immédiatement de rouler.
- Ne vous engagez pas dans des discipline extrêmes, telles que des sauts, lors de l'utilisation du TetraRack.
- N'essayez pas d'utiliser le TETRARACK comme siège passager.
- Équilibrez toujours la charge sur le TetraRack. N'installez pas un sac à sacoches uniquement d'un côté du TetraRack.

## 警告

- 安裝前請擦拭車架，確保安裝位置無油污。
- 請勿負載超過產品的最大荷重。TETRARACK 為16公斤(35磅)，水壺架安裝每側最大負重：3公斤(6磅)
- 每次騎乘前請檢查貨架是否穩固。若有鬆脫請重新安裝後再使用；騎乘中若發生貨架搖晃鬆脫，請立即停止騎乘。
- 使用貨架時請勿從事跳躍、飞跃等極限運動。
- 請勿使用本產品乘載人。
- 不能只裝單側的側袋，且要注意兩側的重量平衡

## WARRANTY

2-year Warranty: All mechanical components against manufacturer defects only.

## Warranty Claim Requirements

To obtain warranty service, you must have your original sales receipt. Items returned without a sales receipt will assume that the warranty begins on the date of manufacture. All warranties will be void if the product is damaged due to user crash, abuse, system alteration, modification, or used in any way not intended as described in this manual.

\* The specifications and design are subject to change without notice.

Please contact your Topeak dealer with any questions. For USA customer service, call: 1-800-250-3068 www.topeak.com

## GEWÄHRLEISTUNG

2 Jahre Gewährleistung auf alle verbauten Teile, jedoch nur gegen Herstellermängel.

## Gewährleistungsansprüche

Sie benötigen Ihren Originalkaufbeleg um den Gewährleistungs-Service zu erhalten. Bei Artikel die ohne Kaufbeleg eingesendet werden, wird davon ausgegangen, dass die Gewährleistung mit dem Herstellungsdatum beginnt. Alle Gewährleistungs- ansprüche werden ungültig, wenn der Artikel auf Grund eines Unfalls beschädigt oder zweckentfremdet wurde, Systemänderungen oder andere Veränderungen vorgenommen wurden oder der Artikel anderweitig verwendet wurde als in diesem Handbuch beschrieben.

\* Änderungen in Design und Eigenschaft bedürfen keiner vorherigen Ankündigung.

Topeak Produkte sind ausschließlich im Fahrradfachhandel erhältlich. Bitte nehmen Sie Kontakt mit Ihrem nächsten Topeak Händler auf, um offene Fragen zu klären. Für Kunden in Deutschland, Tel. 0261-899998-28.

## GARANTIE

Garantie de 2 ans : toutes parties mécaniques contre tout défaut de fabrication.

## Demande de garantie

Pour bénéficier de notre service de garantie, vous devez être en possession de la facture d'achat originale. Si le produit nous est retourné sans cette facture d'achat, nous considérons la date de fabrication comme début de la garantie. Toute garantie sera considérée comme nulle si le produit à été endommagé suite à une chute, à un abus, une surcharge, à un quelconque changement ou modification ou à une utilisation autre que celle décrite dans ce manuel.

\* Les spécifications et l'apparence peuvent être sujettes à certaines modifications.

Contactez votre revendeur Topeak si vous avez a moindre question.

For USA customer service call : 1-800-250-3068 / www.topeak.com

## GARANTÍA

Disponen de 2 años de garantía : Todos los componentes mecánicos con algún defecto de fabricación.

## Condiciones de garantía

Para obtener la garantía debe disponer del justificante de compra, sin el recibo de compra se considerará como fecha de inicio de la garantía la fecha de fabricación. No se considerarán cubiertos por la garantía los artículos dañados por golpes, abuso o alteraciones del sistema, modificaciones, o utilización de otra manera o para otros usos a los descritos en este manual.

\* Las especificaciones y diseño están sujetos a cambios sin notificación previa.

Per favor, contacte con su distribuidor Topeak para cualquier pregunta. garantias@servixtt.com www.servixtt.com, www.topeak.com

## GARANZIA

2 Anni di garanzia : solo per difetti elettronici e meccanici di fabbricazione.

## Condizioni di garanzia

Per usufruire della garanzia è necessario essere in possesso dello scontrino originale di acquisto. In caso il prodotto ci venga restituito senza lo scontrino la garanzia decorrerà dalla data di fabbricazione. La garanzia decade qualora il prodotto venga danneggiato da uso improprio, sovraccarico, modifiche o utilizzato in maniera diversa da quella descritta nelle presenti Istruzioni di uso.

\* Le caratteristiche del prodotto possono essere cambiate senza preavviso.

I prodotti Topeak sono in vendita nei negozi specializzati per ciclisti. Per ogni richiesta o chiarimento rivolgetevi al rivenditore Topeak più vicino. Sito web: www.topeak.com

## NOTAS DE ADVERTENCIA

- Limpie el área de montaje en el cuadro/horquilla antes de instalar TetraRack.
- Nunca exceda la capacidad de máxima de carga cuando utilice TETRARACK M2 HD (35 lb / 16 kg) ni la carga máxima del soporte del portabidón en cada lado: 6 lb / 3 kg.
- Verifique que TetraRack esté bien montado después de cada viaje. Si hay algún movimiento exagerado del TetraRack durante un viaje, deje de usarlo inmediatamente.
- No realice rutas extremos, saltos, cuando utilice TetraRack.
- No intente utilizar TETRARACK como asiento de pasajero.
- Siempre equilibre la carga en TetraRack. No instale una alforja solo en un solo lado del TetraRack.

## NOTE DI AVVERTIMENTO

- Pulire l'area di montaggio del telaio/forcella prima di installare TetraRack.
- Non superare mai la capacità di carico massima quando si utilizza il TETRARACK M2 HD (35 lb / 16 kg) e il carico massimo del supporto per portaboraccia su ciascun lato: 6 lb / 3 kg
- Controllare TetraRack dopo ogni attività per verificarne il montaggio sicuro. Se si verifica un movimento eccessivo del TetraRack durante la guida, interrompere immediatamente l'attività.
- Non intraprendere attività di guida estreme, come i salti, quando si utilizza TetraRack.
- Non tentare di utilizzare il TETRARACK come sedile del passeggero.
- Bilanciare sempre il carico su TetraRack. Non montare una borsa laterale solo su un lato di TetraRack.

## WARNING NOTES

- Przed montażem TetraRack oczyszcz obszar mocowania ramy/widelca.
- Nie przekraczaj maksymalnego obciążenia TETRARACK M2 HD (16 kg) i uchwytu koszyka bidonu. Maksymalne obciążenie z każdej strony: 13 kg
- Po każdej jeździe sprawdź, czy TetraRack jest dobrze zamocowany. Jeśli podczas jazdy nastąpi nadmierny ruch TetraRack, należy natychmiast przerwać jazdę.
- Podczas korzystania z TetraRack nie uprawiaj ekstremalnej jazdy, takiej jak skakanie
- Nie próbuj używać TETRARACK do wozenia pasażera.
- Zawsze zrównowaz bagaz na TetraRack. Nie montuj torby podróznzej tylko po jednej stronie TetraRack

## 注意

- テトララックを取り付ける前に、フレーム、フォークの取り付け部分の汚れを取り除いてください。
- 最大荷重16kg(天板)、3kg(ボトルケージマウント片側)を超えないよう注意してください。
- 乗車前にテトララックが正しく取り付けられているか確認してください。走行中にテトララックが意図せず動くようなどは、直ちに走行を中止してください。
- テトララックをご使用の際は、ジャンプなどの激しいライディングをしないでください。
- テトララックに人を座らせないでください。
- パンニアック等を取り付けるときは、片側だけに取り付けず、両側に取り付けてください。

## 경고

- TetraRack을 장착하기 전 장착 부위(프레임/포크)를 청소하십시오.
- TETRARACK M2 HD를 사용할 때 최대 적재 용량(35lb/16kg)을 초과하지 마십시오.
- 측면의 각 물방 케이지 마운트 최대 적재량은 6lb/3kg입니다.
- 사용 전 TetraRack을 점검하고 정확히 이상이 없는지 확인하십시오.
- 주행 중 TetraRack의 흔들림이 발생하는 경우 즉시 주행을 멈춰 이상 유무를 확인하십시오.
- TetraRack이 장착되어 있는 상태에서 점프 등 과격한 라이딩을 하지 마십시오.
- TetraRack을 보조안장으로 사용하지 마십시오.
- TetraRack의 하중은 항상 균형을 유지시켜야 합니다. 물건을 몰아서 적재하거나 한쪽에만 패니언백을 설치하지 마십시오.

## 警告

- 安裝前請擦拭車架，確保安裝位置無油污。
- 請勿負載超過產品的最大荷重。TETRARACK 為16公斤(35磅)，水壺架安裝每側最大負重：3公斤(6磅)
- 每次騎乘前請檢查貨架是否穩固。若有鬆脫請重新安裝後再使用；騎乘中若發生貨架搖晃鬆脫，請立即停止騎乘。
- 使用貨架時請勿從事跳躍、飛躍等極限運動。
- 請勿使用本產品乘載人。
- 不能只裝單側的側袋，且要注意兩側的重量平衡

## GAWARANCJA

2 lata gwarancji: Na wady fabryczne wszystkich części mechanicznych.

Warunki korzystania z gwarancji

Abi uzyskać serwis gwarancyjny, należy posiadać oryginalny dowód zakupu. Gdy produkt reklamowany jest bez paragonu zakładamy, że gwarancja rozpoczyna się od daty produkcji. Wszystkie gwarancje sa niewazne jeśli produkt został uszkodzony na skutek wypadku, nadużycia, zmiany, modyfikacji lub wykorzystany w jakikolwiek sposób niezgodny z opisaniem w niniejszej instrukcji.

\* Specyfikacja i projekt mogą ulec zmianie bez powiadomienia.

W przypadku jakichkolwiek pytań skontaktuj się ze sprzedawcą lub importerem Topeak.

## 保証期間

ご購入日より2年間：製造上の欠陥による機械部品の不良が対象です。

## 保証の請求

保証を受けるには、ご購入日の日付の入った領収書が必要です。領収書なしで保証を受ける場合の保証期間は製造年月 日から起算させていただきます。お客様の事故などによる外因要因、誤使用、改造、およびこの取扱説明書に従わない本来の用途以外のご使用による故障 は保証を受けられません。故障した製品は故障状況を明記して、お買上げの販売店へお持ちください。お送りになる場合の送料はお客様にてご負担をお願いします。

\* スペックやデザインは改良のため予告なく変更されることがあります。

トピーク製品は全国有名自転車店でお買い求めいただけます。

お問い合わせは、最寄りのトピーク正規販売店へどうぞ。

Website: www.topeak.jp

## 품질보증

제한적 2년 품질 보증 : 소비자 과실을 제외한 제조과정상 모든 요인에 대하여 2년간 보증합니다.

## 품질 보증을 위한 필요조건

품질 보증 서비스를 받기 위해서는 반드시 원본 구매 영수증을 제시해야 합니다. 구매 영수증이 없는 경우, 모든 제품은 그 제품의 가장 최초의 제조일로부터 3개월 후를 구입일로 인정합니다. 본 제품을 사용 중 외부의 충격으로부터

손상을 받았거나 사용자의 오용, 남용, 임의 개조, 변형 또는 사용설명서에 기술한 내용에 맞지 않게 사용된 경우 품질 보증을 받을 수 없습니다. \* 제품의 체원이나 디자인은 사전 공지 없이 변경될 수 있습니다.

토피크의 제품은 전문 대리점에서 구입 가능합니다. 제품문의: (주)하이엔드스포츠 TEL.031-8022-7510

회사사이트 : www.hscc.co.kr, www.topeak.com

## 產品保固

## 保固要求

申請保固期限中的服務，須檢具購買時之發票，若無法提供，則其保固期限將自製造日期開始算起。若因使用者不慎摔壞、使用不當、自行改裝、更改系統或未能按照說明書上的正確操作方式，本產品將不被列入保固範圍。

\* 本公司保留產品規格變更之權利。

Topeak 產品相關的資訊，請洽詢 Topeak 當地授權的經銷商。

網址：www.topeak.com

## 产品保固

## 保固要求

申請保固期限中的服務，須檢具購買時之發票，若無法提供，則其保固期限將自製造日期開始算起。若因使用者不慎摔壞、使用不當、自行改裝、更改系統或未能按照說明書上的正確操作方式，本產品將不被列入保固範圍。

\* 本公司保留產品規格變更之權利。

Topeak 產品相關的資訊，請洽詢 Topeak 當地授權的經銷商。

網址：www.topeak.com